

Cable and QD hookups are functionally identical

Sensing Mode and Range		Beam	Model*	Output
Retroreflective	5 m (15')	Visible Red 650 nm	SME312LV	Bipolar NPN/PNP
	Polarized Retroreflective		10 mm - 3 m (0.4" - 10')	
1 m (3.3') Clear Material		SME312LPC		
Diffuse	380 mm (15")	Infrared 880 nm	SME312D	
	1100 mm (43")	Visible Red 650 nm	SME312DV	
Convergent	16 mm (0.65") 1.3 mm (0.05") [†]	Visible Red 650 nm	SME312CV	
			SME312CV2	
	16 mm (0.65") 1.0 mm (0.04") [†]	Visible Green 525 nm	SME312CVG	
			16 mm (0.65") 1.8 mm (0.07") [†]	
	Visible White 450 - 650 nm	SME312CVW		

[†] Spot size, at focus

Sensing Mode and Range		Beam	Model*	Output
Glass Fiber Optic	Range Varies depending on sensing mode and fiber optics used	Infrared 880 nm	SME312F	Bipolar NPN/PNP
		Visible Red 650 nm	SME312FV	
		Visible Green 525 nm	SME312FVG	
		Visible Blue 475 nm	SME312FVB	
		Visible White 450 - 650 nm	SME312FVW	
Plastic Fiber Optic	Range Varies depending on sensing mode and fiber optics used	Visible Red 650 nm	SME312FP	
		Visible Green 525 nm	SME312FPG	
		Visible Blue 475 nm	SME312FPB	
		Visible White 450 - 650 nm	SME312FPB	

* Standard 2 m (6.5') cable models are listed.

• 9 m (30') cable: add suffix "W/30" to the model number (e.g., SME312CVB W/30).

• 5-pin integral QD models: add suffix "Q" (e.g., SME312CVBQ).

Dimensions

Retroreflective, Diffuse, and Convergent Models
(Suffix LV, LP, LPC, D, DV, CV, CV2, CVG, CVB and CVW)

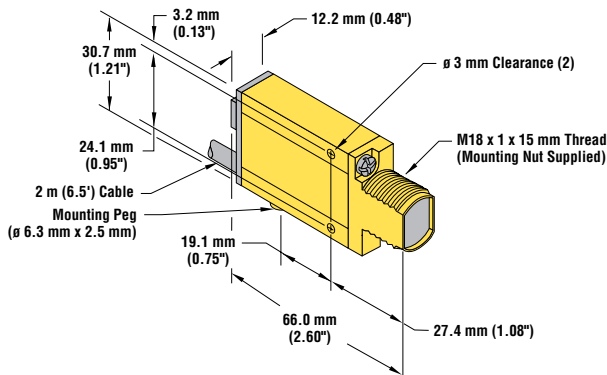

All Quick-Disconnect Models

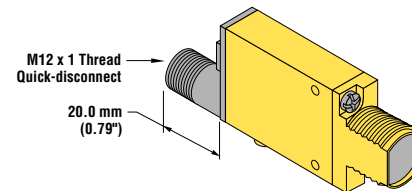

MINI-BEAM® Expert™ Series – DC Voltage

Dimensions, continued

Divergent Diffuse Models (Suffix W)

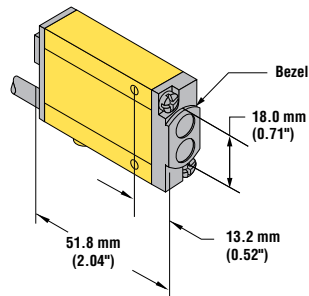

Glass Fiber Optic Models (Suffix F, FV, FVG, FVB and FVW)

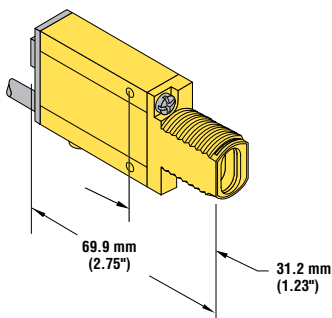

Plastic Fiber Optic Models (Suffix FP, FPG, FPB and FPW)

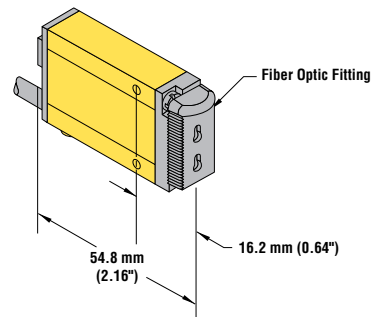

Overview

Status indicators

Normal operation of the MINI-BEAM *Expert* is called RUN mode. The two LED indicators (bi-color Green/Red and Yellow) operate as follows in RUN mode and TEACH mode:

	RUN Mode	TEACH Mode
Bi-Color Green/Red	ON Green: Power is ON Flashing Green: Sensed light level is approaching sensing threshold*	ON Red: Sensor "sees" its own modulated light source; pulse rate is proportional to the received light signal strength**
Yellow	ON: Outputs conducting OFF: Outputs not conducting	ON: Ready to TEACH output ON condition OFF: Ready to TEACH output OFF condition

* This is the Stability indicator, which signals when maintenance, realignment, or reconfiguration is needed during RUN mode.

** The faster the pulse rate, the stronger the light signal.

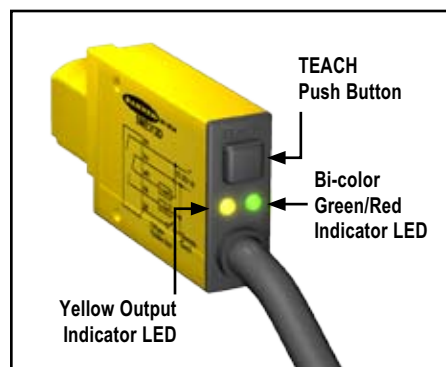

Figure 1. Features

If contrast is marginal, the bi-color indicator will flash green (to indicate instability). Reprogramming or realigning the sensor, or cleaning the sensor or fiber lenses may solve a problem with stability.

Remote Configuration

The remote function may be used to configure the sensor remotely or to disable the push button for security. Connect the gray wire of the sensor to ground (0V dc), with a remote programming switch connected between them. Pulse the remote line according to the diagrams in the configuration procedures. The length of the individual programming pulses is equal to the value T:

$$0.04 \text{ seconds} \leq "T" \leq 0.8 \text{ seconds}$$

Troubleshooting

The MINI-BEAM *Expert's* Power LED may begin to alternate flashing red/green; this indicates a microprocessor memory error. If it occurs, try reteaching the sensor, or try cycling power ON and OFF, then reteaching the sensor. If this does not solve the problem, or if it occurs frequently, replace the sensor.

MINI-BEAM® Expert™ Series – DC Voltage

Specifications

Supply Voltage and Current

10 to 30V dc (10% max. ripple) at less than 45 mA, exclusive of load

Supply Protection Circuitry

Protected against reverse polarity and transient voltages

Output Configuration

Bipolar: One current sourcing (PNP) and one current sinking (NPN) open-collector transistor

Output Rating

150 mA max. each output at 25° C, derated to 100 mA at 70° C (derate \approx 1 mA per °C)

Off-state leakage current: less than 5 μ A @ 30V dc

ON-state saturation current: less than 1V @ 10 mA; less than 1.5V @ 150 mA

Output Protection Circuitry

Protected against false pulse on power-up and continuous overload or short-circuit of outputs

Output Response Time

Sensors will respond to either a "light" or a "dark" signal of 500 μ s or longer duration, 1 kHz max.

NOTE: 1 second delay on power-up; outputs do not conduct during this time.

Repeatability

100 microseconds (all models)

Construction

Reinforced thermoplastic polyester housing, totally encapsulated, o-ring seal, acrylic lenses, and stainless steel screws.

Environmental Rating

Meets NEMA standards 1, 2, 3, 3S, 4, 4X, 6, 12, and 13; IEC IP67

Connections

PVC-jacketed 5-conductor 2 m (6.5') or 9 m (30') unterminated cable, or 5-pin Euro-style quick-disconnect (QD) fitting are available. QD cables are ordered separately.

Operating Conditions

Temperature: -20° to +70° C (-4° to +158° F)

Max. rel. humidity: 90% at 50° C (non-condensing)